

# Linear Wet Tray Installation Instructions

Please ensure all tradesmen working on or around the installation have consulted these instructions and understand how to maintain the waterproofing integrity.

## Linear Wet Tray Guarantee

If installed correctly by a competent person and used for normal wetroom applications the Linear Wet Tray (and membrane if supplied by us as a kit) have a life-of-tiling guarantee (if grout lines are maintained). No guarantee is offered where this is not the case.

## Installation Overview

These instructions assume the wetroom has been appropriately designed and all plumbing and electrical work is to building regulations. These instructions will cover the most typical level floor installations on suspended timber or solid concrete floors. For raised floors areas the instructions can be applied where appropriate.

The Linear Wet Tray requires under-boarding

## Installation on Timber Floors

If setting the deck into an existing timber floor first remove the floorboards to expose the joists in the area where the deck will be fitted.

Inspect the integrity of the existing joists and if in doubt remedial action should be taken to ensure the floor is strong and stable.

Under board the entire tray area using 18mm plywood level with the top of the joists. Support with at least 38 x 38mm timber battens screwed to the side of the joists, also batten between the joists to support the ends of the plywood.

It can be beneficial to leave the plywood loose at this stage until the waste is fitted as this will allow you better access to make final waste connections.

1. Measure, mark out and cut floorboards

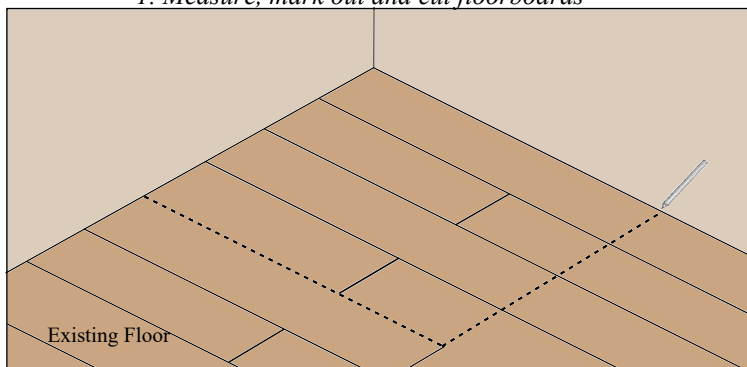

2. Remove floorboards to expose joists

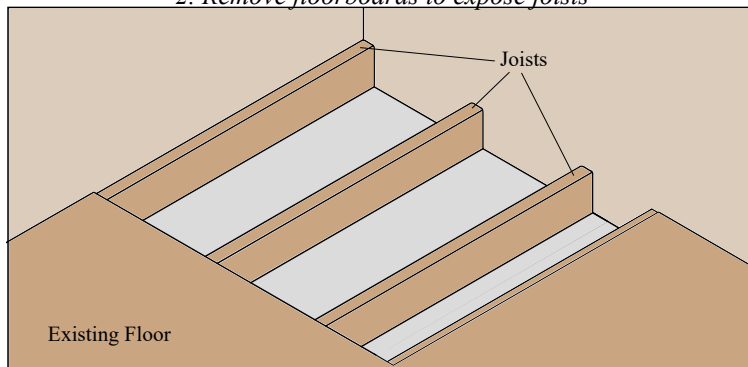

3. Install timber battens between joists

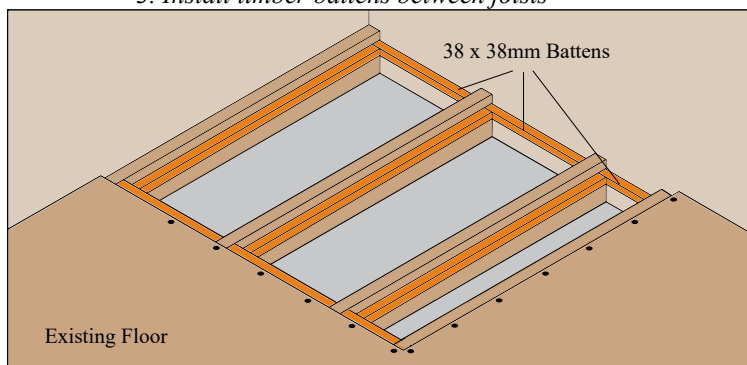

4. Fit plywood between joist

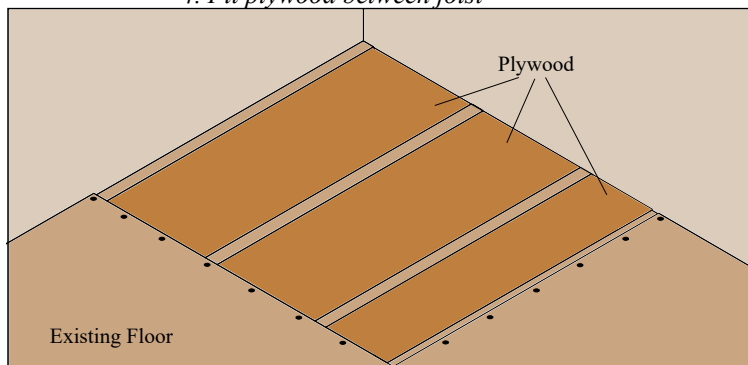

Lay the deck down into position and draw around the drain slot rectangle.  
 Remove the deck and lay the supplied 6mm MDF spacer within the drawn rectangle, draw around the internal shape then remove it with a jigsaw.  
 Align the MDF spacer over the hole and place the drain on top. Pilot drill through the drain flange and spacer and fix securely down.  
 Connect the waste pipe, the supplied 40mm reducer is a solvent-weld fitting.  
 Screw down all plywood at 230mm centres.  
 Apply a thin layer of flexible tile adhesive to the plywood (may need priming first) or rear of the deck and lay into position, press firmly down. Check levels and insert screws or add weights to ensure accuracy of levels and allow to dry.

5. Lay down deck, draw around drain slot

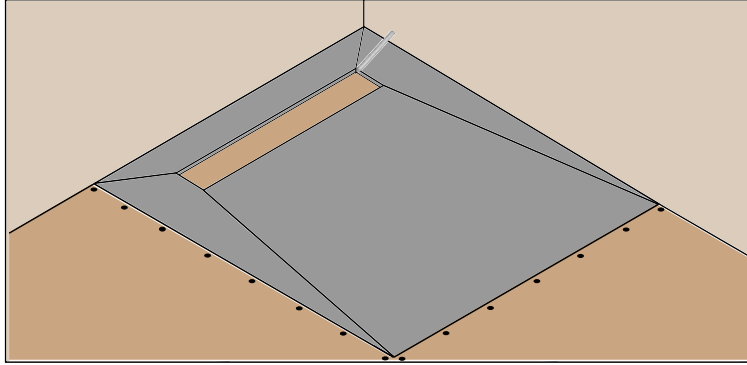

6. Mark around inside of MDF packer, remove, then cut out

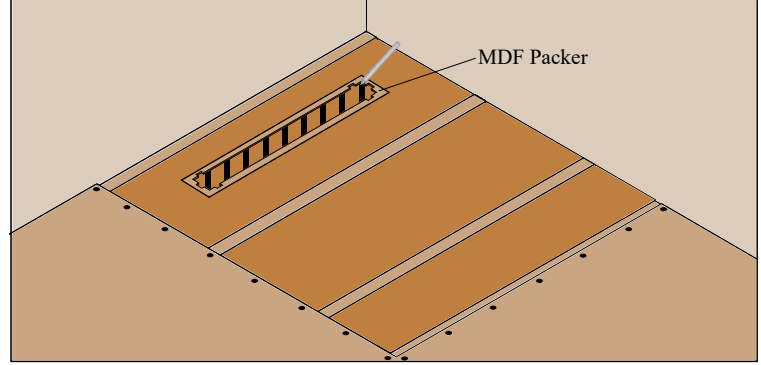

7. Insert drain through packer and secure.

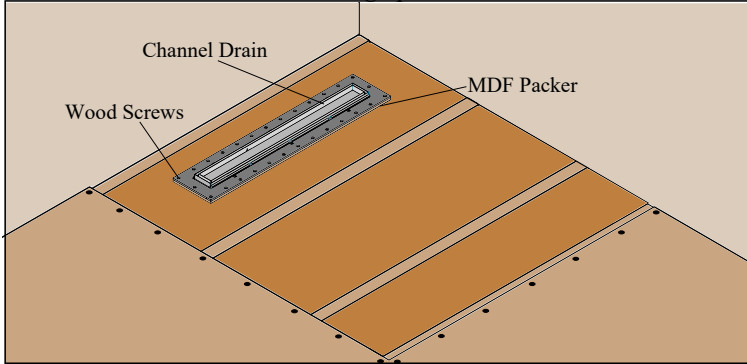

8. Stick deck down with tile adhesive.

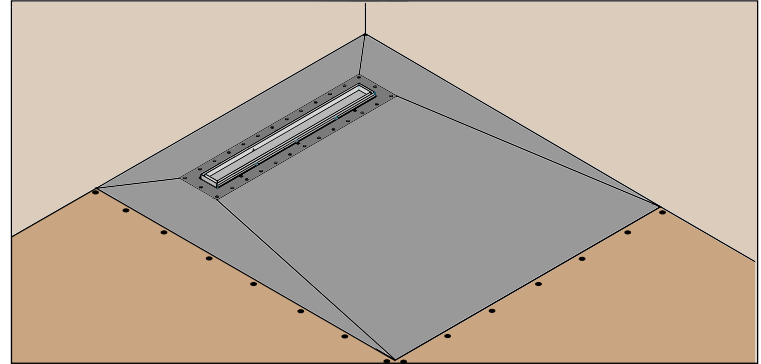

## Installation on Concrete Floors

The Linear Wet Tray may be installed inset into the concrete to create a level access wet area or straight on top of the concrete.

If fitting the deck inset into concrete the area beneath the deck must be cut and chiseled out to create a recess of 35mm to accommodate the deck.

Mark the location of the drain and chase out for it and the waste pipe.

Install the drain into the floor so the channel drain plastic flange is level with the top surface of the deck when laid over the top, making sure that in turn the deck is level with the existing floor.

Using sand and cement or tile adhesive fill the area around the channel drain making sure to fill in all the gaps.

Bed the deck down on tile adhesive making sure of a solid bed and that there are no cavities under the deck.

Check levels, screws or weights maybe used to level off.

Allow to dry.

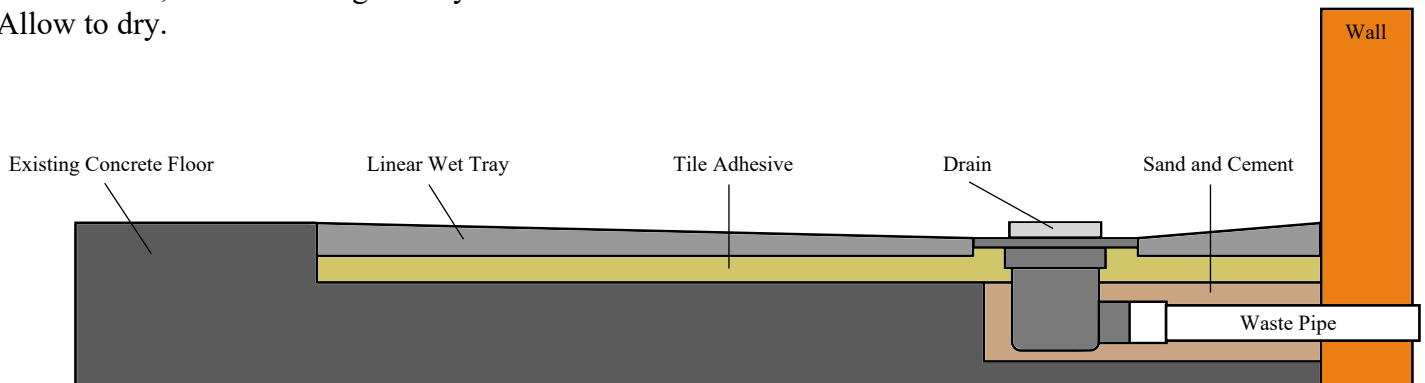

## **Finishing**

The white drain collar is laid over the top of the drain and tanked in between two coats of the paint of tanking system. The rest of the installation should also be tanked appropriately.

Depending how the Linear Wet Tray is installed the floor may need to be levelled to the same height as the deck, this may be done using Plywood, Screed or Tile backer board.

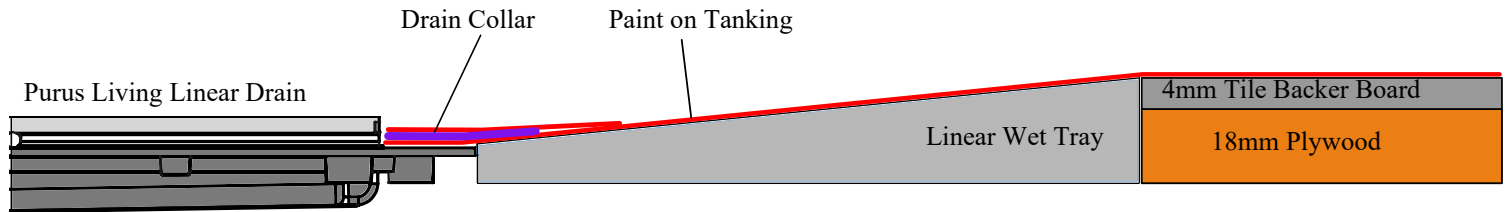

Tile up to the drain frame which will leave space for a grout line. The patterned grid and frame (Drop and Twist) can be height adjusted using the screws to accommodate different tile thickness. The tile insert grid and frame is designed to accommodate 10mm tiles.

Tile Insert

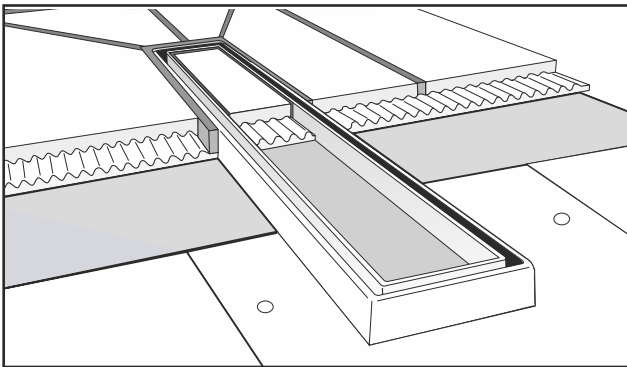

Twist Grid

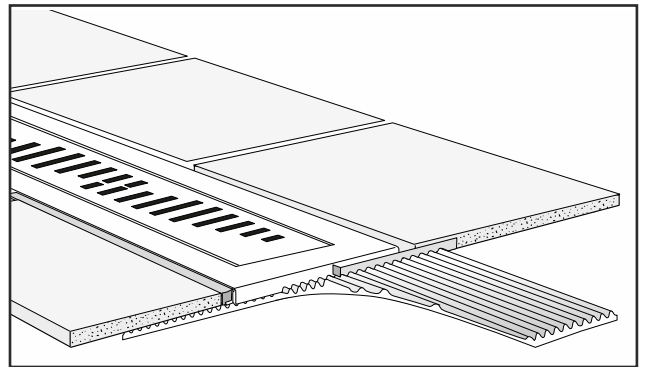

## **Safety and Important Notes**

If any components are damaged or missing, do not install; contact your distributor straight away.

Tile adhesive should be flexible bag powder S1 or S2 suitable for wet areas.

Do not use power tools on the screws of the Purus Living Wetroom Drain.

The grate when installed must be horizontal and flat. It also must be level with the tile surface and not at an angle or slope.

Check where all pipes, electrical cables and all other services are prior to drilling, cutting and screwing into walls, ceilings and floors.

Safety goggles, masks and gloves should be worn at all times.

## Cleaning and Maintenance

Lift out the NOOD water trap as shown.

If necessary, rinse the NOOD water trap using water. Hold the NOOD with the spring loaded body fully open whilst rinsed clean.

Only use water and if required, a small brush to clean the NOOD. It is important that you do not use bleach, bleach-based, caustic cleaning products or hair dye products on or in the NOOD water trap. Remove the NOOD first.

If bleach, deblocker or any other cleaning product is to be used in the pipework then the NOOD water trap should be removed first.

Replace the NOOD water trap with two thumbs at each short end.

Make sure the gaskets are completely clean so the NOOD is watertight. Ensure when placed back that the gully is fully inserted.

If you have a blockage in the waste pipe system, remove the NOOD before rectifying/cleaning.

